

INTER-BOARD_100-PIN_CONNECTORS

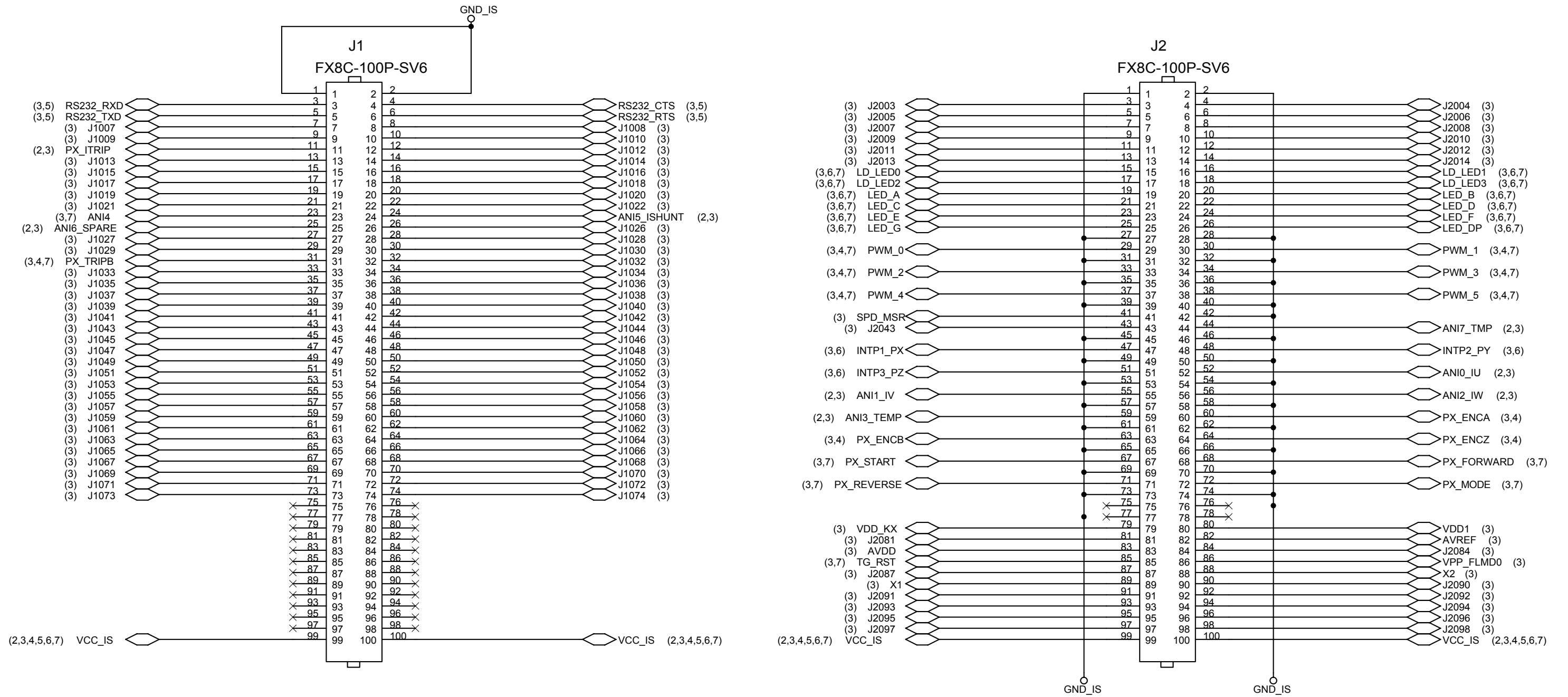

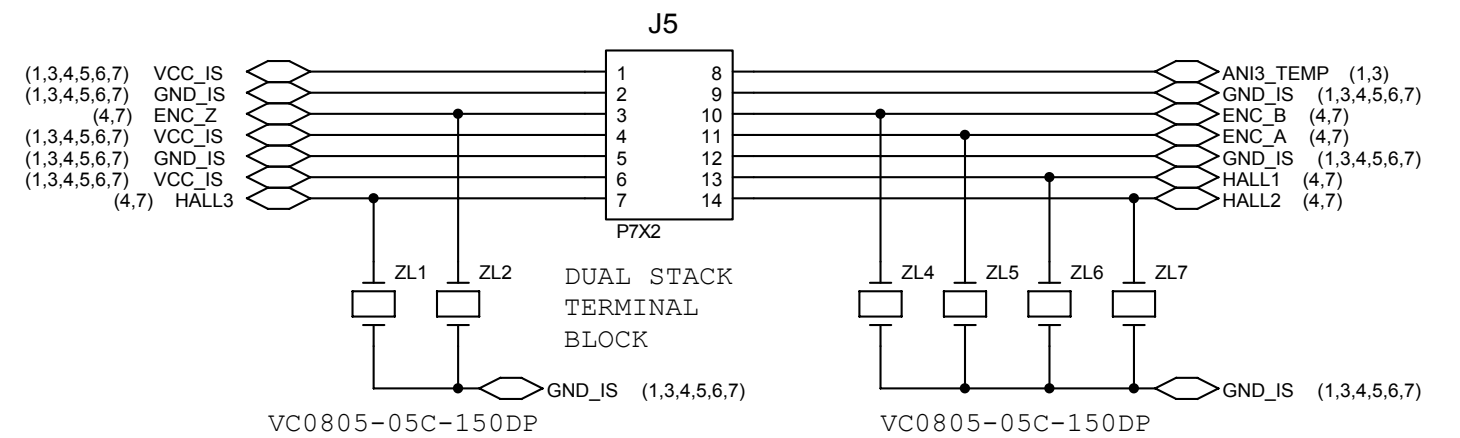

Microsystem Synthesis Inc.		
Title MC-IO J4 J5		
Size B	Document Number MOTOR CONTROL I/O BOARD	Rev 1.0
Date: Wednesday, April 27, 2005	Sheet 2 of 7	1

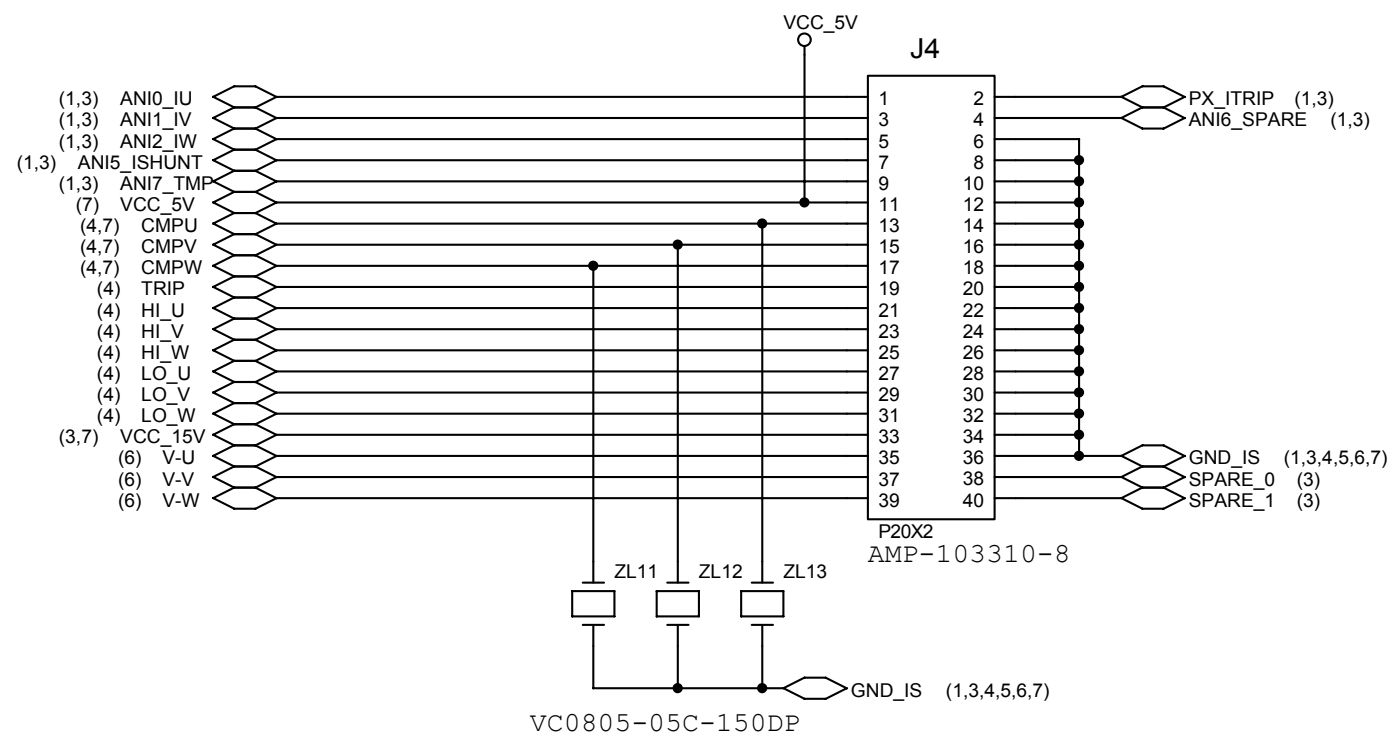
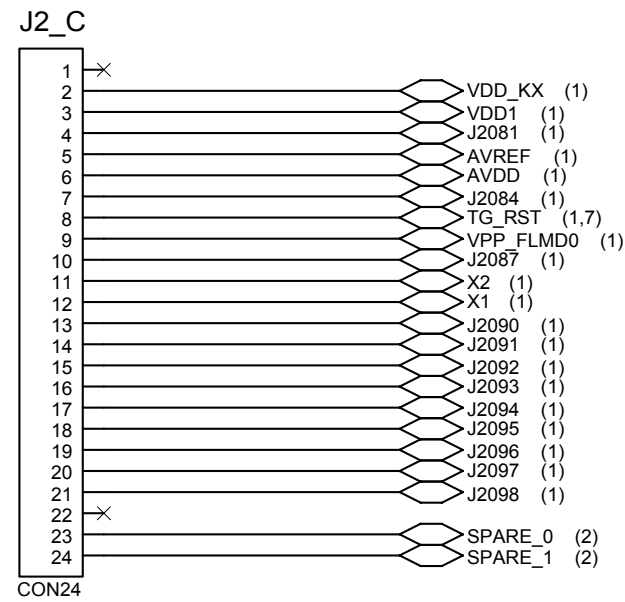
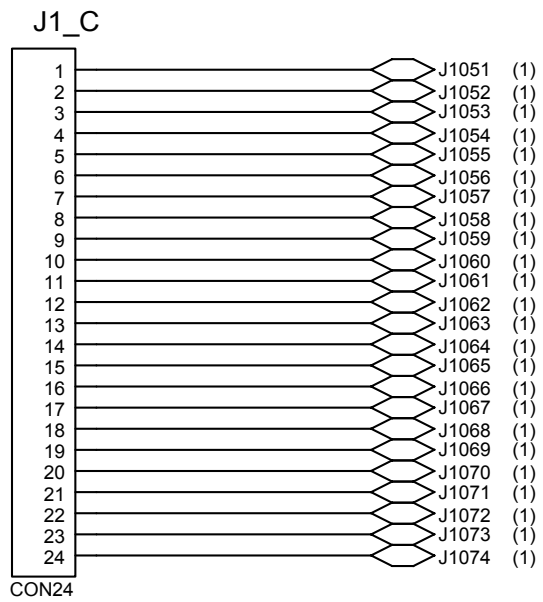
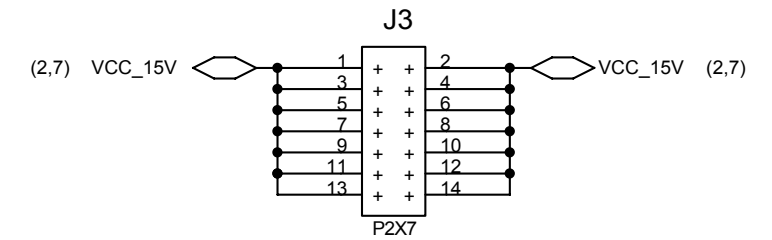
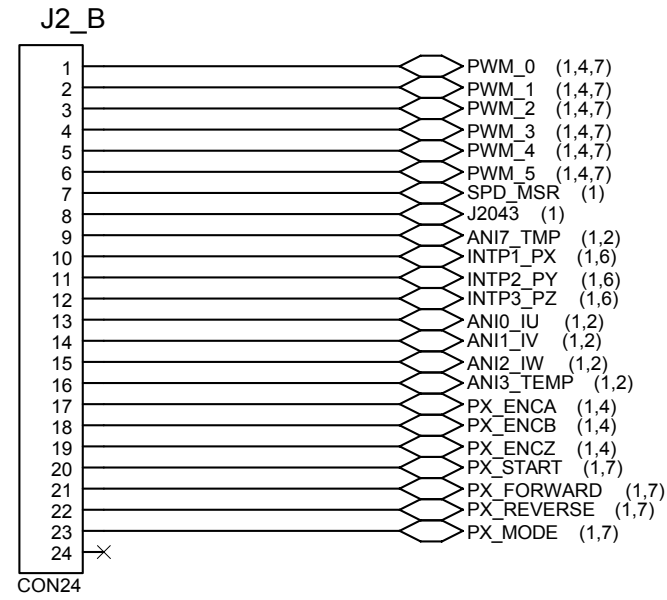
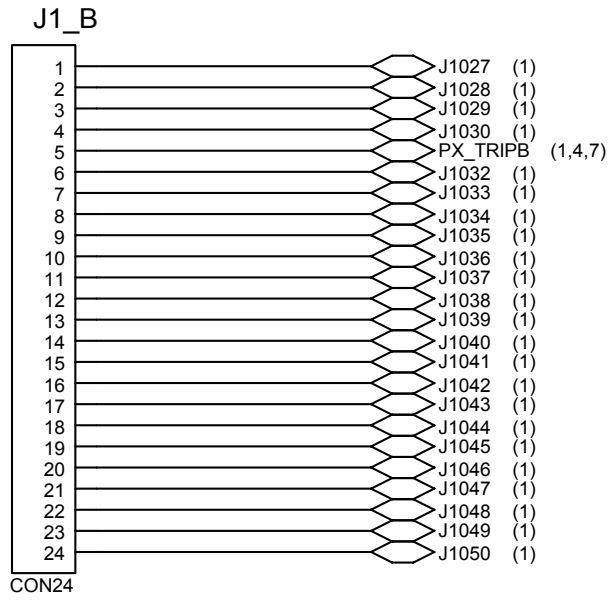
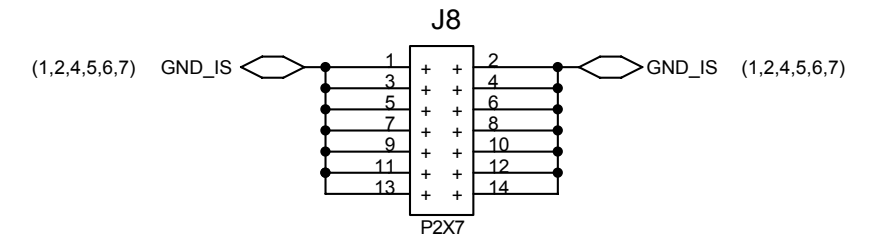
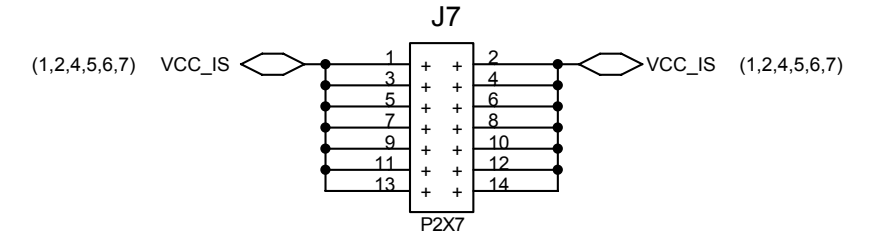
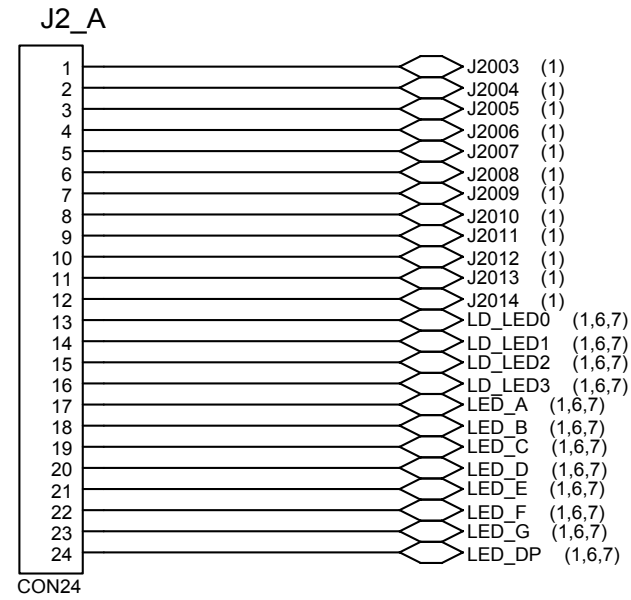
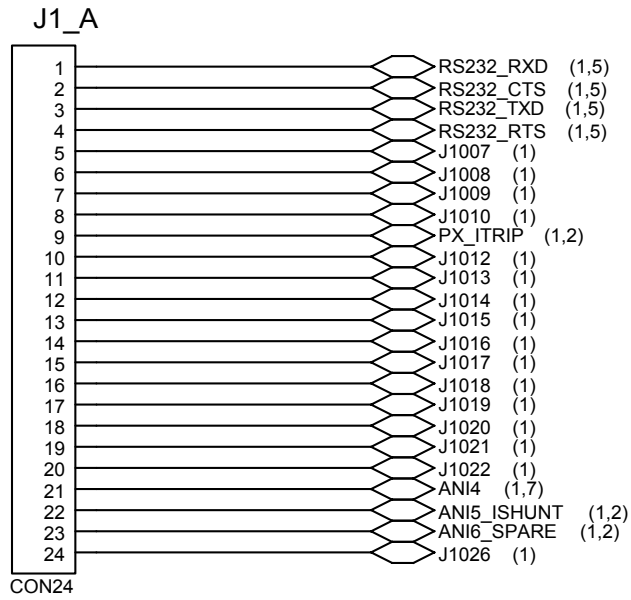

PROTOTYPE AREA
 24 PINS BY 6 COLUMNS
 100-MILS CENTERED PADS

Microsystem Synthesis Inc.		
Title MC-IO PROTOTYPE		
Size B	Document Number MOTOR CONTROL I/O BOARD	Rev 1.0
Date: Wednesday, April 27, 2005	Sheet 3 of 7	

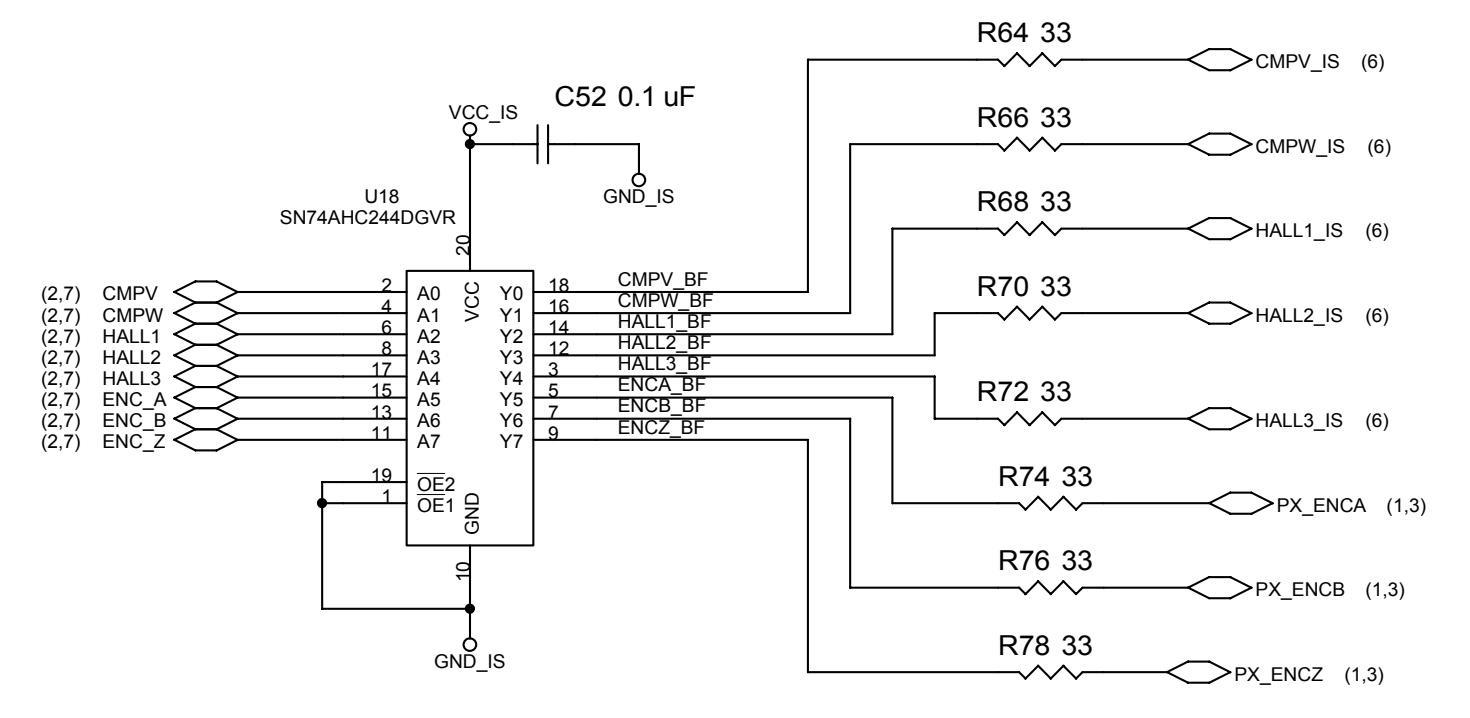
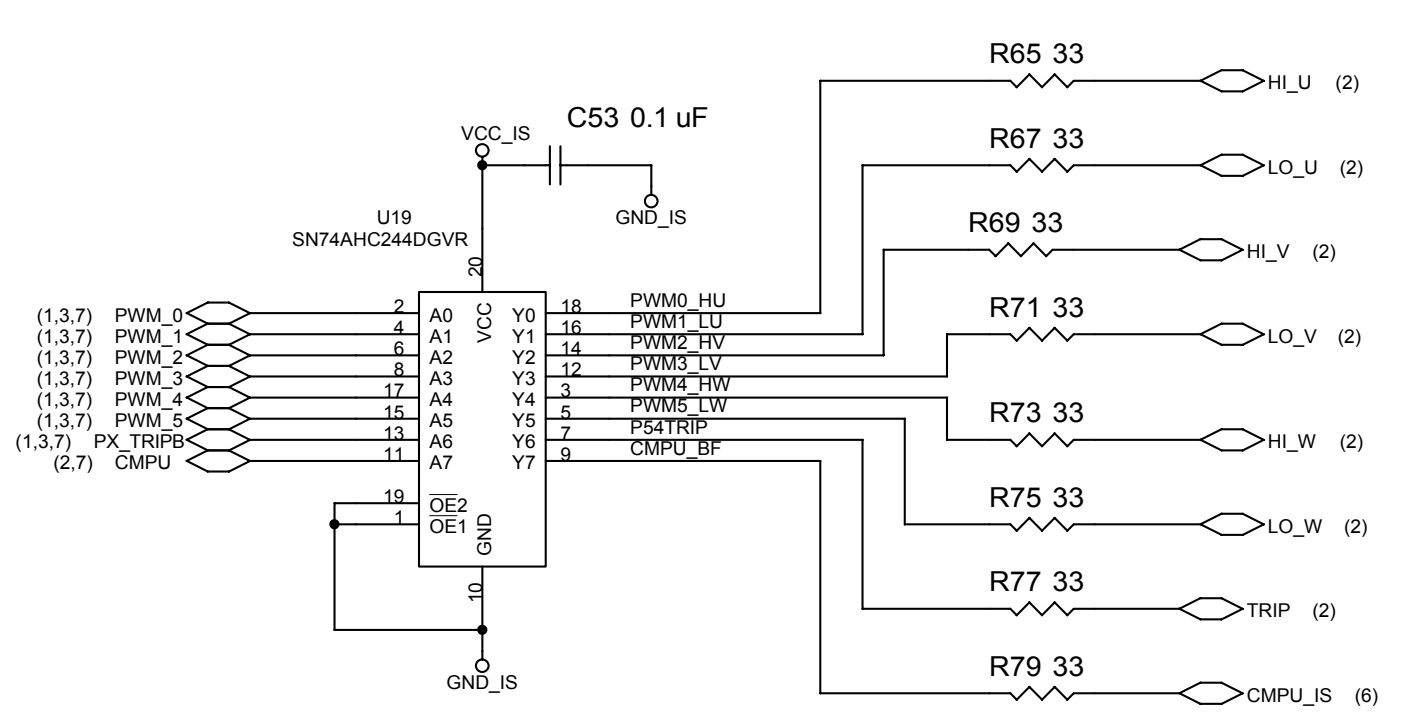

RS232 TRANSCEIVER WITH OPTIONAL DB9 CONNECTOR

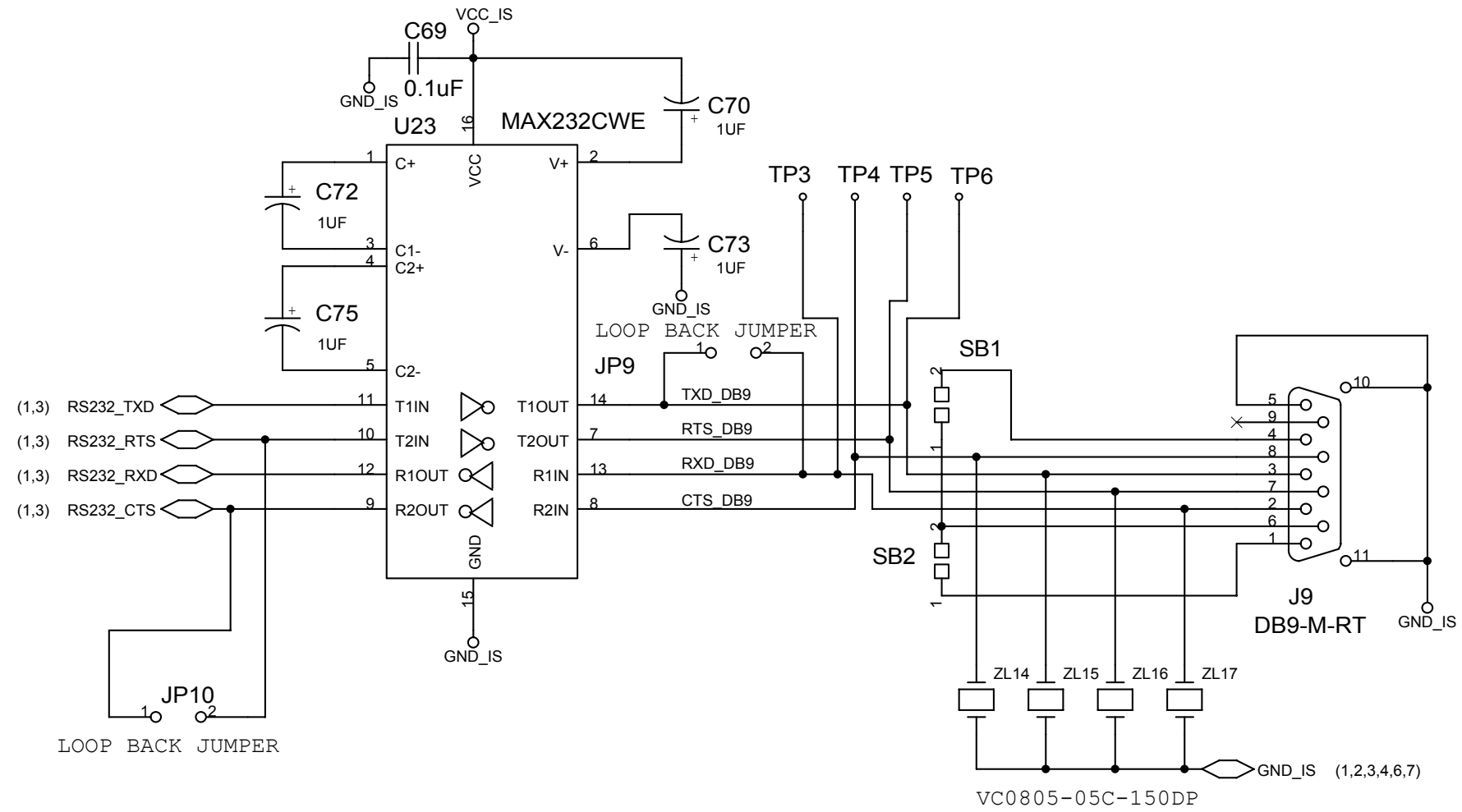

Microsystem Synthesis Inc.		
Title MC-IO RS232 TRANCIEVER		
Size B	Document Number MOTOR CONTROL I/O BOARD	Rev 1.0
Date: Wednesday, April 27, 2005	Sheet 5 of 7	1

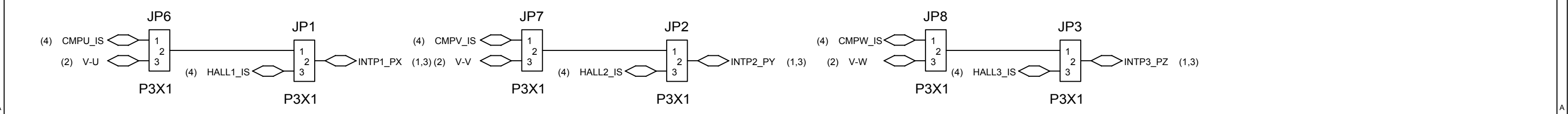
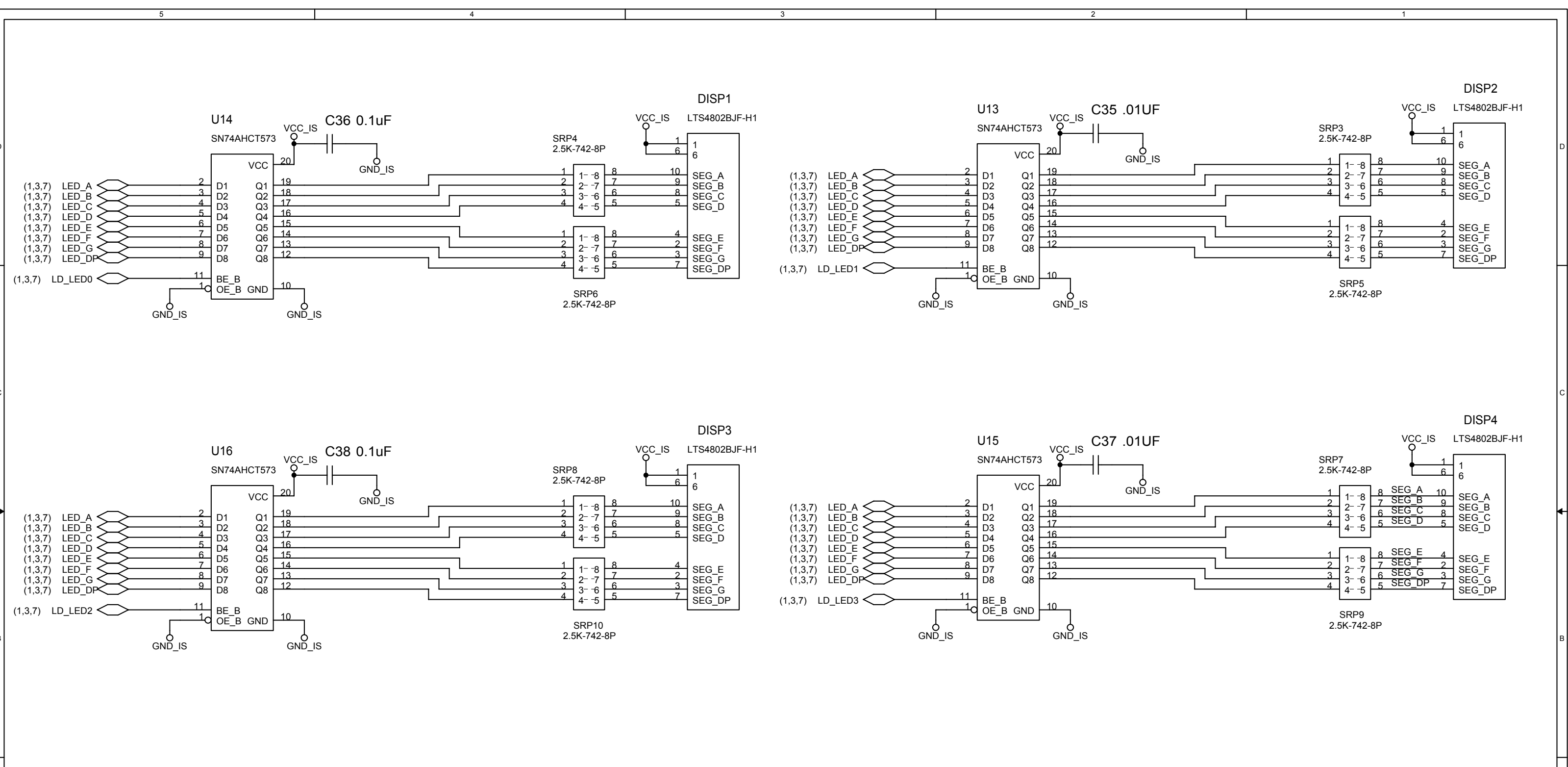

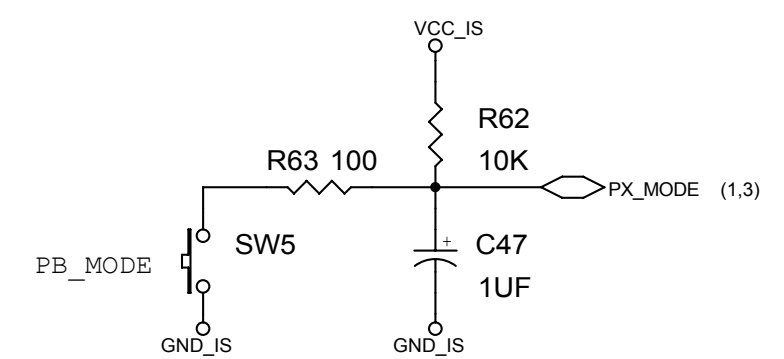
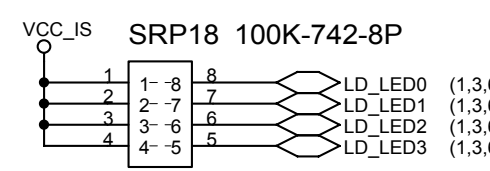
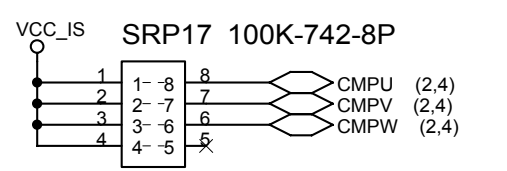
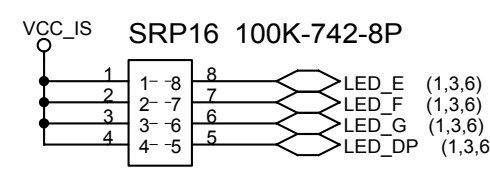
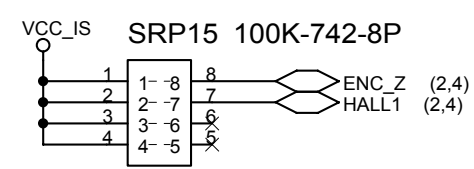
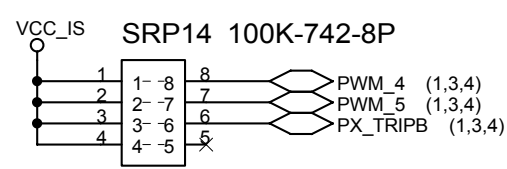
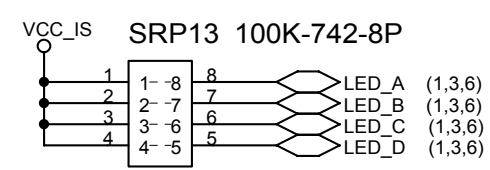
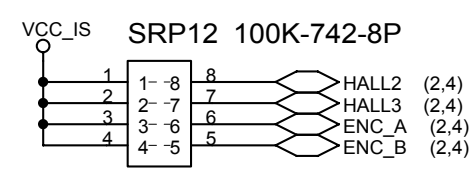
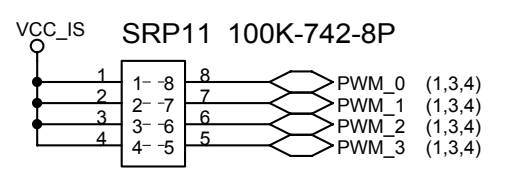
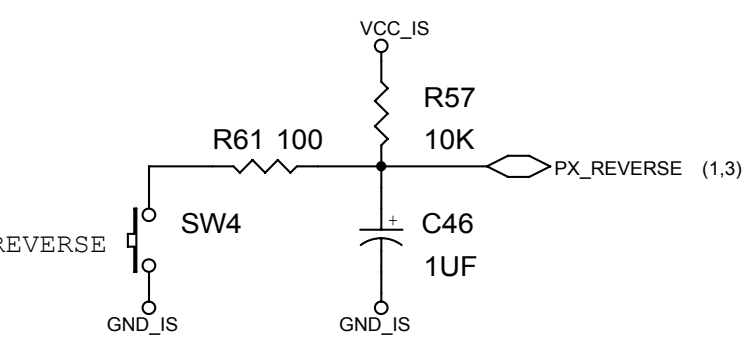
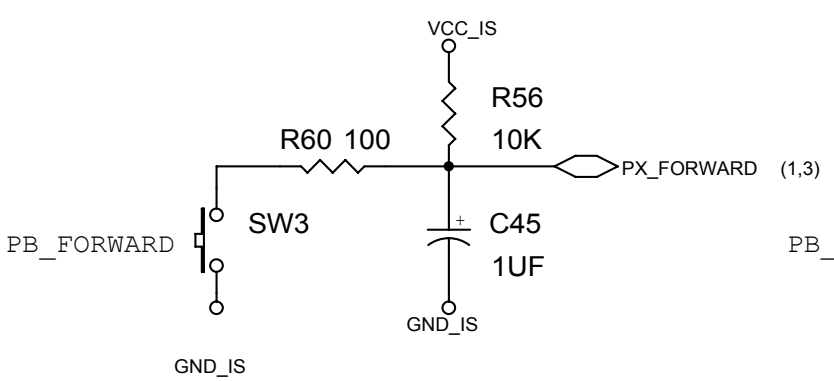
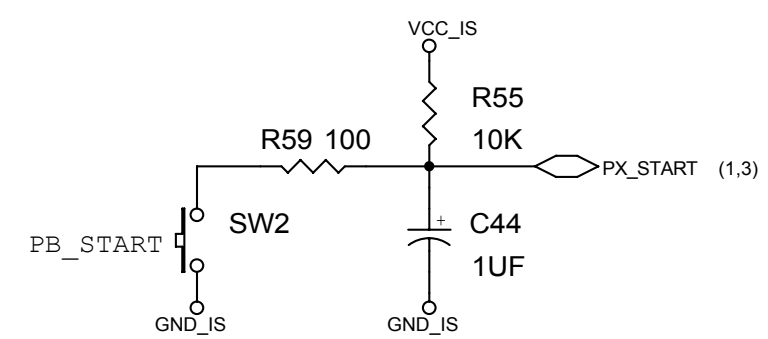
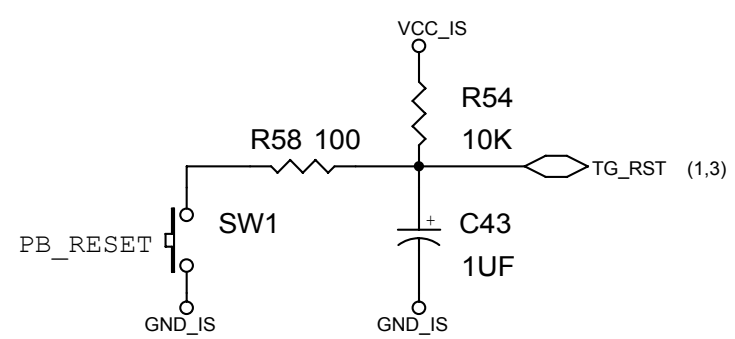
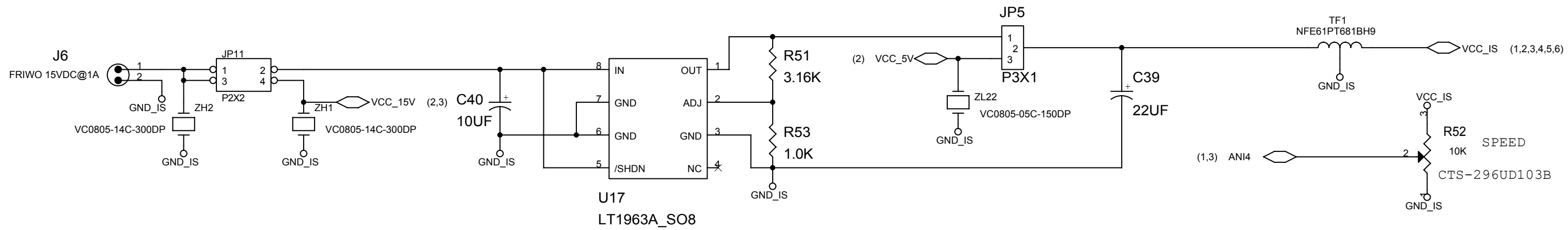

Microsystem Synthesis Inc.		
Title MC-IO REG/VOLT/TERMINATIONS		
Size B	Document Number MOTOR CONTROL I/O BOARD	Rev 1.0
Date: Wednesday, April 27, 2005	Sheet 7 of 7	